

Introduction to Remote Sensing

Just the Basics

Dr Brian Vant-Hull

bvanthull@ccny.cuny.edu

The Big Picture

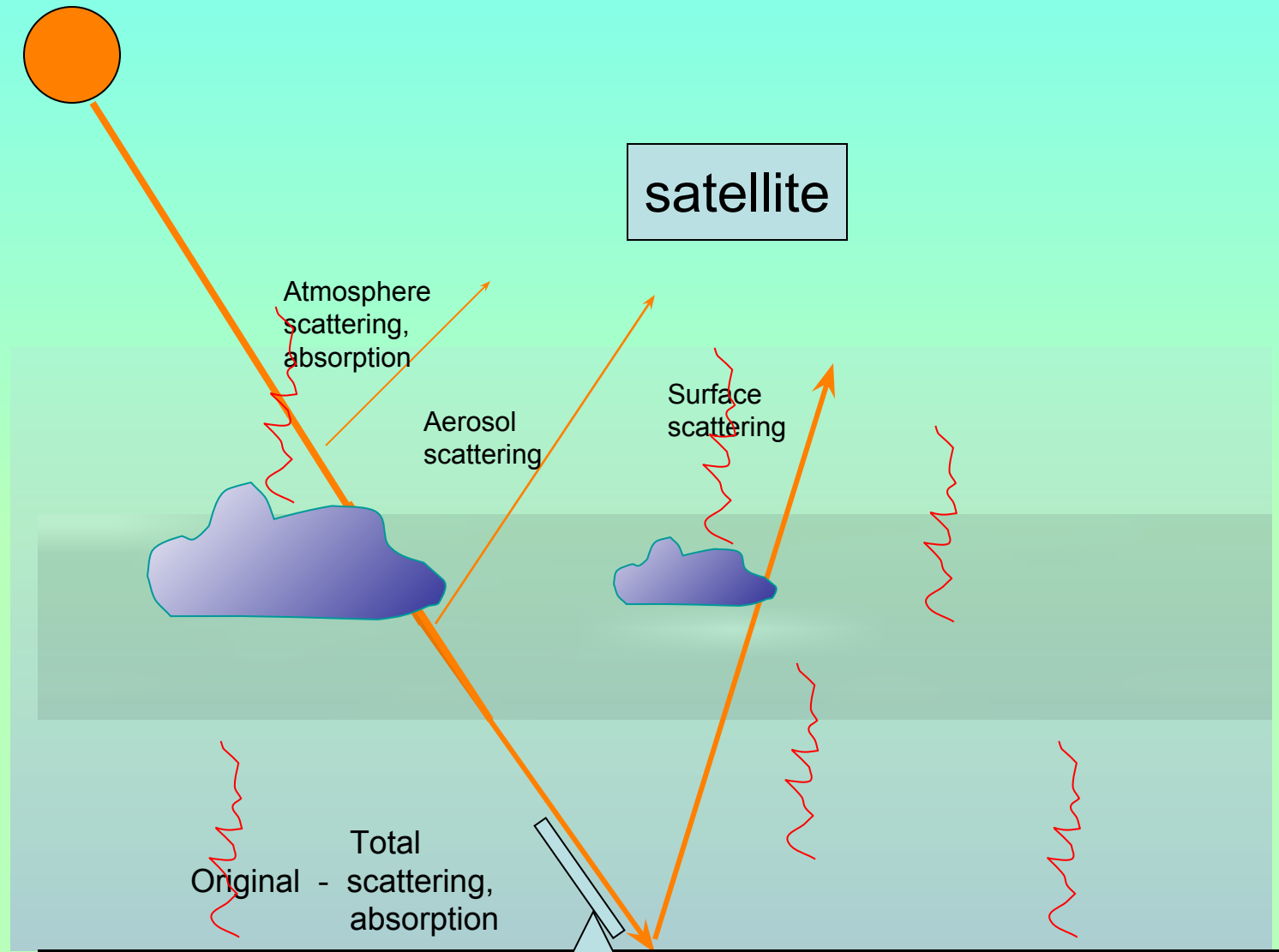

What Will We be Talking About?

- Satellites: orbit types and scanning
- Collimation, Distance, Resolution
- What Light Is and How it is measured
- Conservation of Energy: Absorption and Scattering of Light
- Reflectance
- Detecting Vegetation
- Wave Effects
- Optical Depth

Satellite Orbits

Low polar orbit

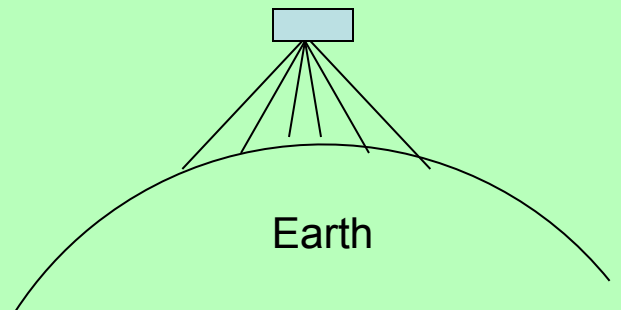
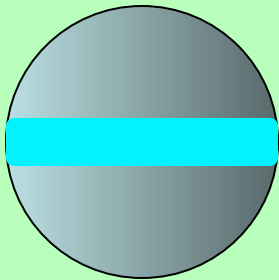

Near Polar Orbits

$T \approx 90$ minutes

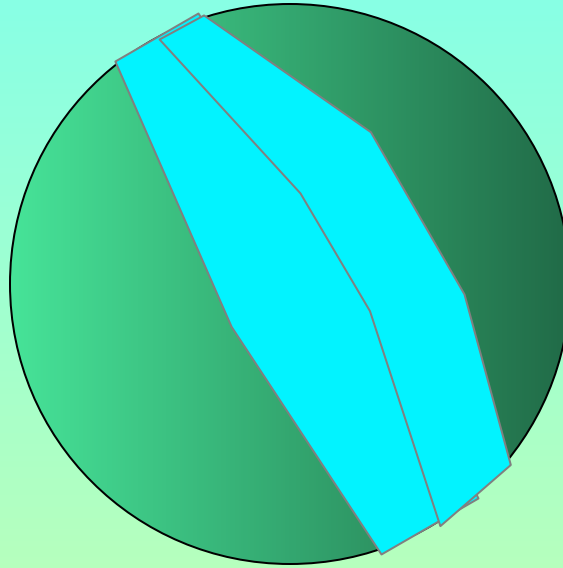

High Resolution
Episodic

Gravitational acceleration = Centripetal acceleration

$$\frac{GM}{r^2} = \frac{v^2}{r}$$

$$v = \frac{2\pi r}{T}$$

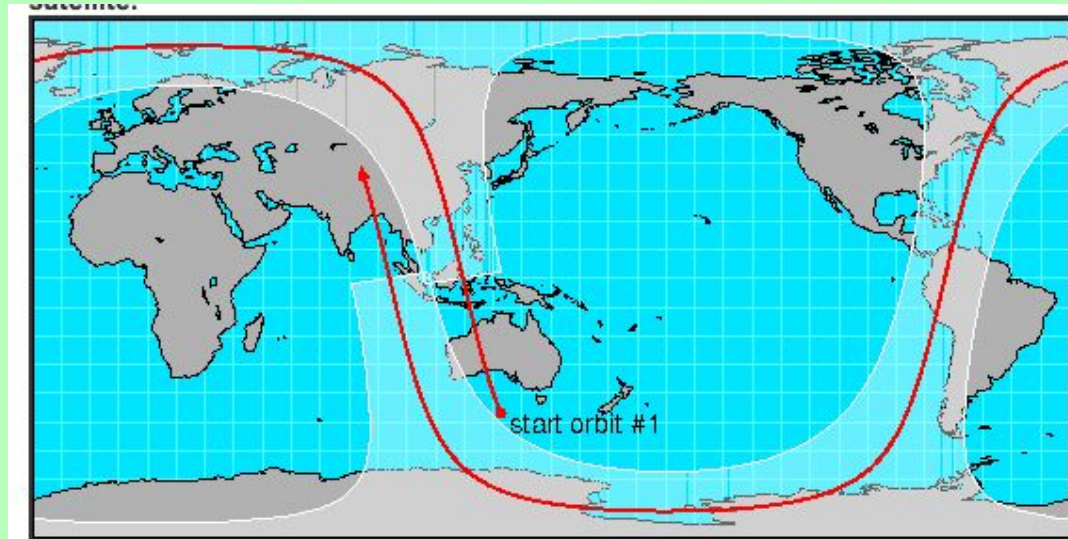

Geosynchronous Orbits

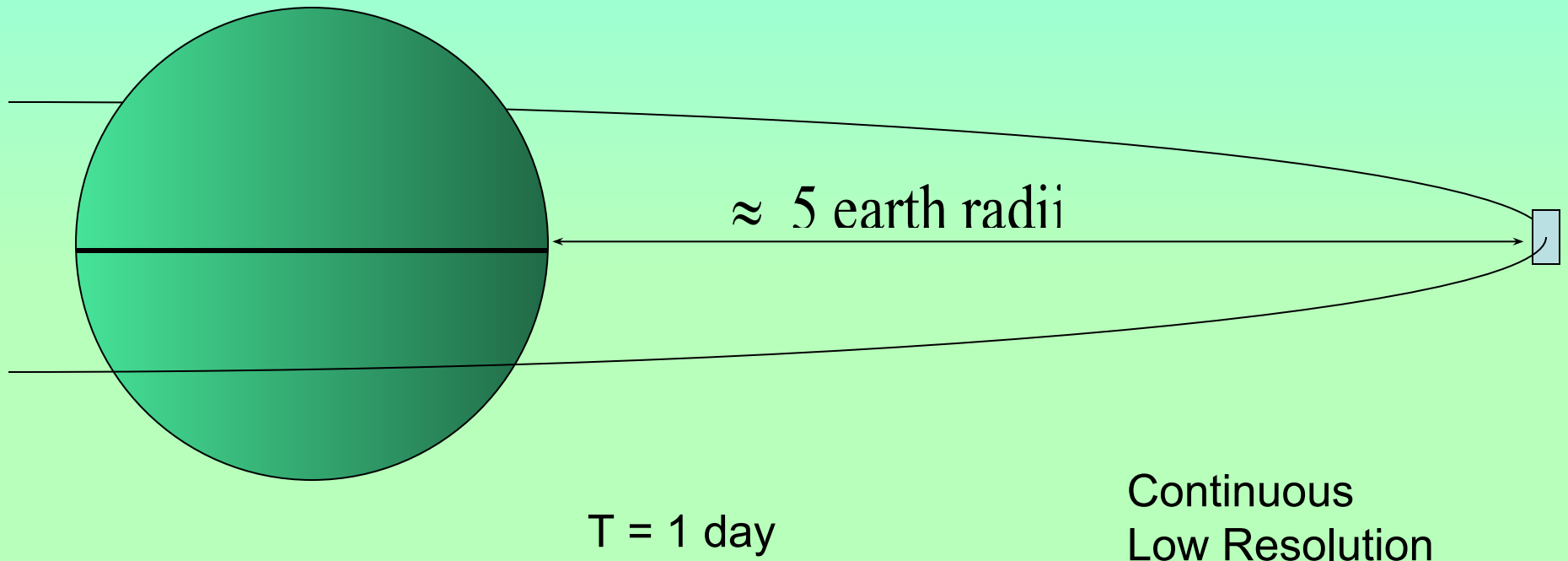

Match the Orbit to the Task

Crop Monitoring

Storm Tracking

Sea Temperature

Fire Detection

Snow Cover

Geosynchronous

(Continuous, coarse pixels)

Low Polar Orbit

(Episodic, fine pixels)

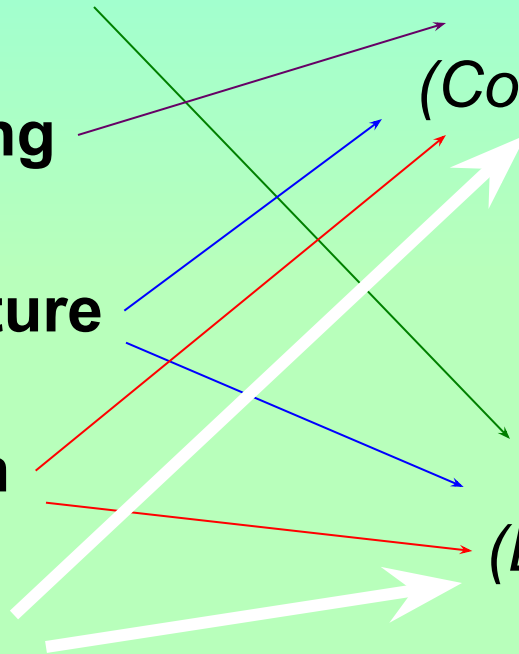

Typical Scan Pattern

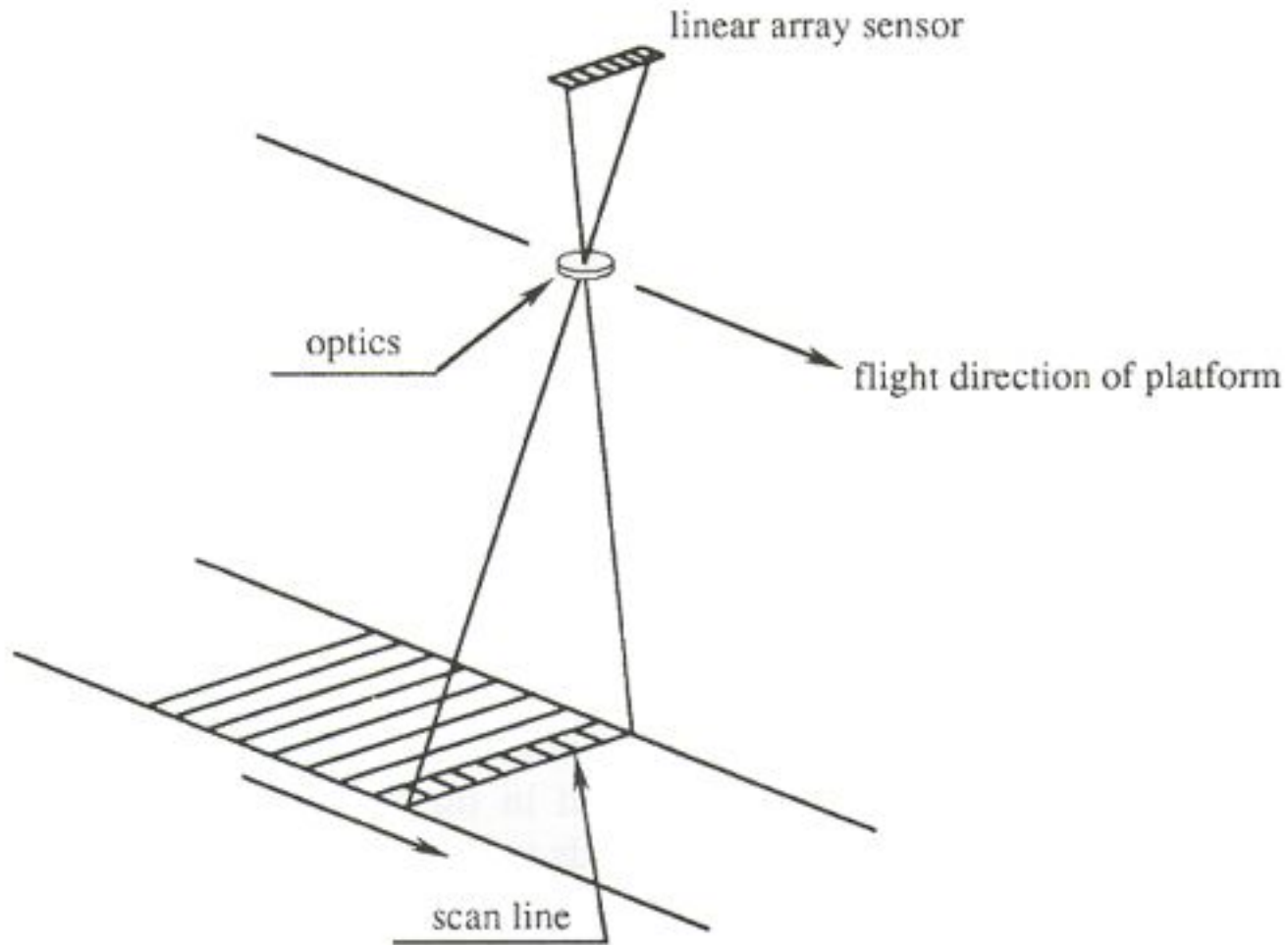

Typical Pixel Distortion

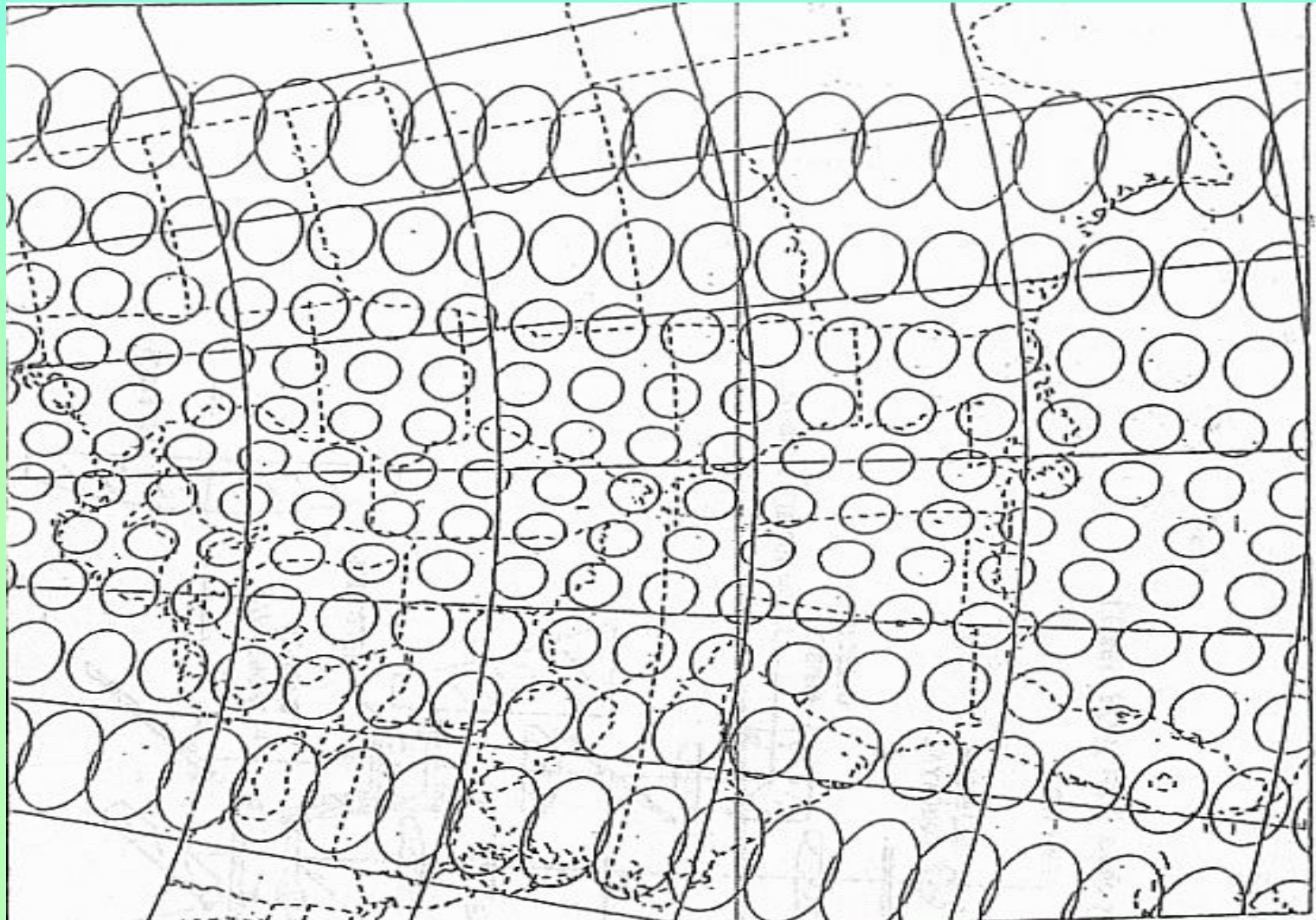

Collimation

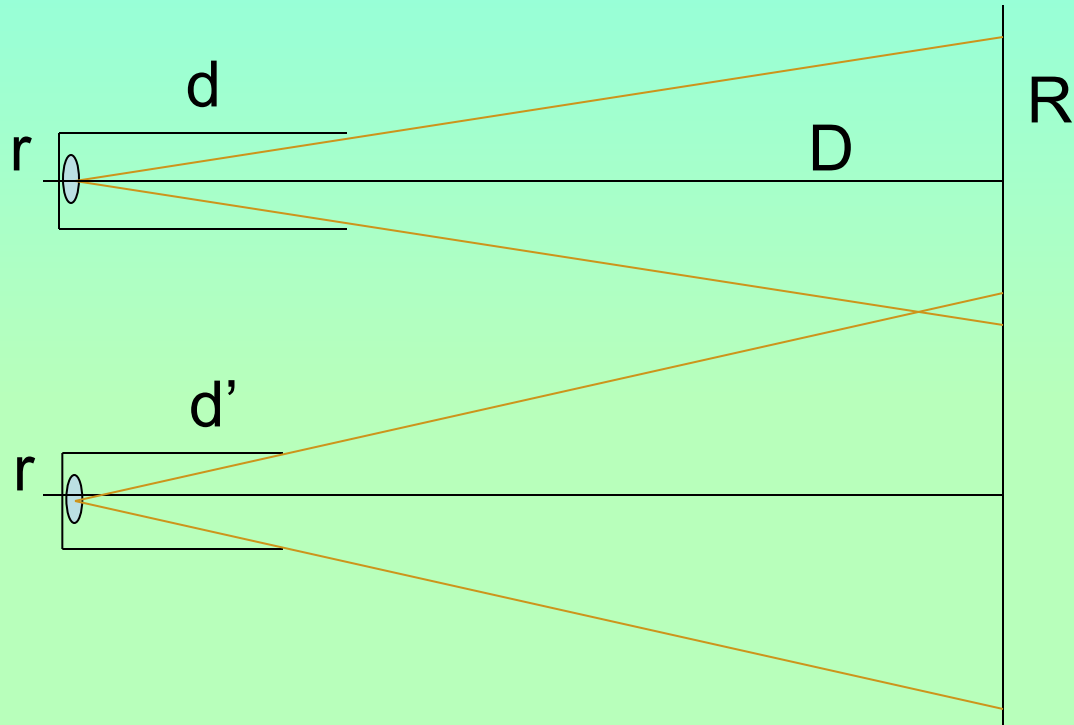

Geometry
affects the
field of view

Example: sunspots on the sun are about the size of the earth. If you wanted to resolve sunspots using the pixels on a scanning camera of a satellite orbiting the earth, if the length of the collimator is 20 cm, what would be the area of the base?

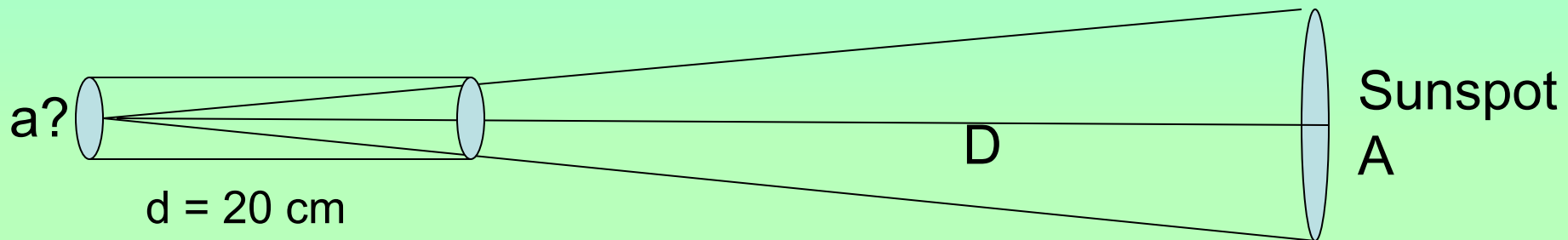

$$r/d = R/D$$

$$a = \pi r^2 \quad A = \pi R^2$$

Length of collimator $d = 20 \text{ cm}$

Area of collimator $a ?$

Distance to sunspot $D = 150 \text{ million km}$

$$\text{Area of sunspot} = \pi r^2 = \pi(C/2\pi)^2 = C^2/4\pi = (4 \times 10^4 \text{ km})/4\pi$$

Corks in a Pond

The diagram shows two brown circular corks floating on a light blue background representing water. From each cork, several concentric black circles radiate outwards, representing waves. The circles from the left cork are larger than those from the right cork, indicating it has been vibrating longer. The waves from the two corks overlap, illustrating how one wave can cause another cork to vibrate and produce its own waves.

A cork bobbing in a pond will send out waves that cause other corks to bob and send out waves.

This is analogous to vibrating charges that produce EM waves that set other charges to vibrate and produce waves: EM waves are both produced and

Basic Wave Stuff

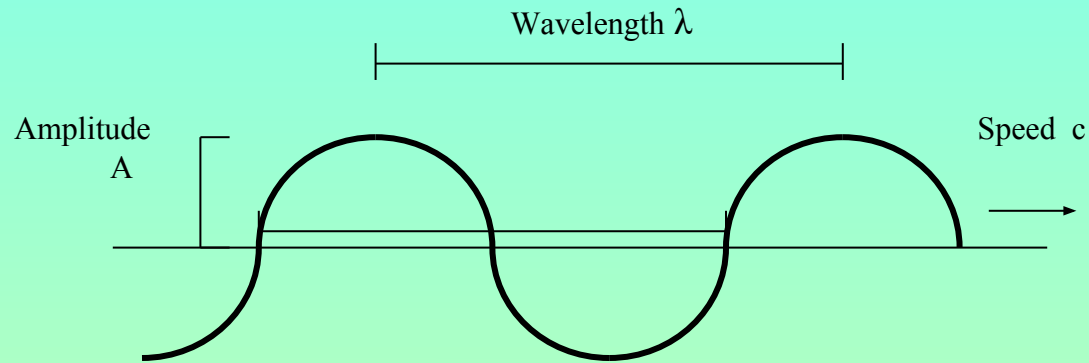

Period $T = \text{seconds/wave}$
Frequency $f = \text{waves/seconds}$

$$f = 1/T$$

Speed $c = \text{distance/time} = \lambda/T = \lambda f$

$$c = \lambda f$$

THE ELECTROMAGNETIC SPECTRUM

Penetrates Earth Atmosphere?



Wavelength (meters)



About the size of...



Frequency (Hz)



Temperature of bodies emitting the wavelength (K)

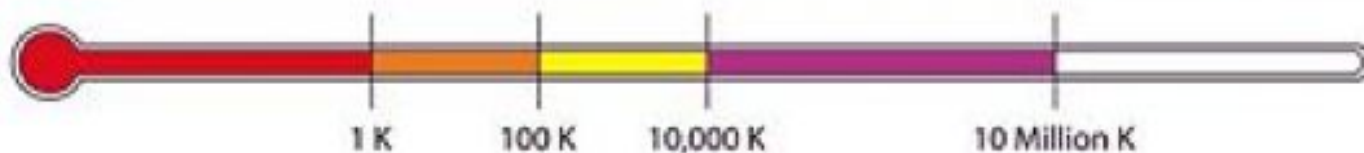

How do we know light is a wave?

The Double Slit Experiment!

Photons and Waves

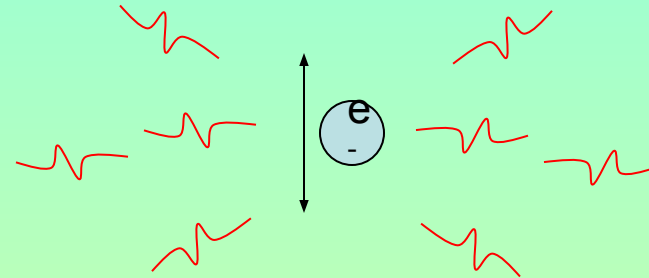
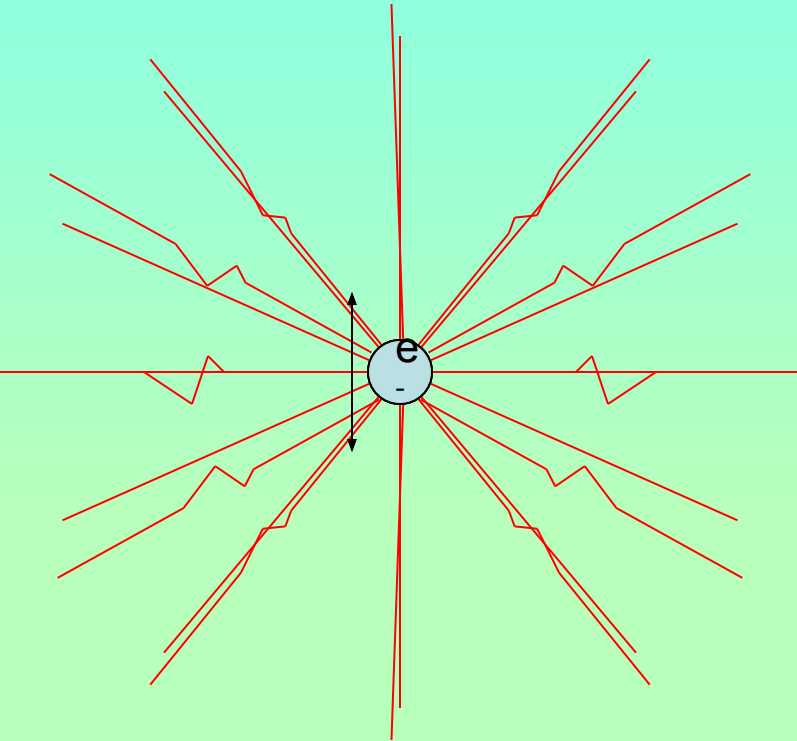

Double Slit Experiment

<https://www.youtube.com/watch?v=Q1YqgPAzho>

Individual photons, two source
interference

12 word summary of quantum mechanics:
“Spatial wave patterns give the probability of
finding particles: wave-particle duality.”

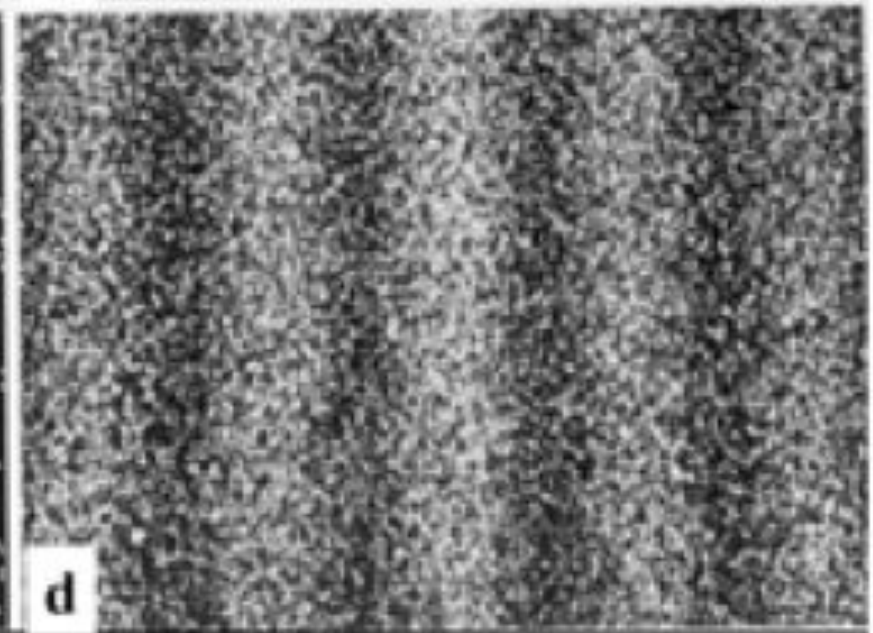
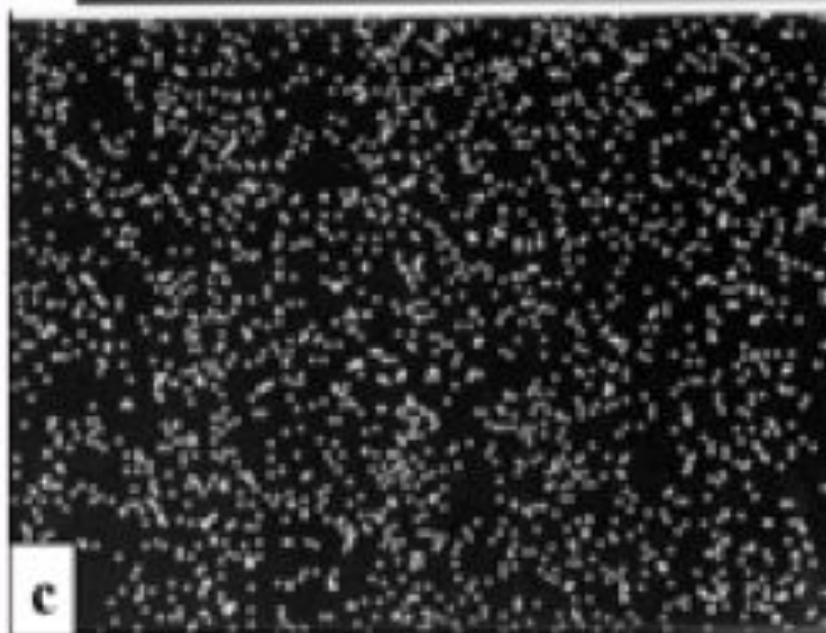
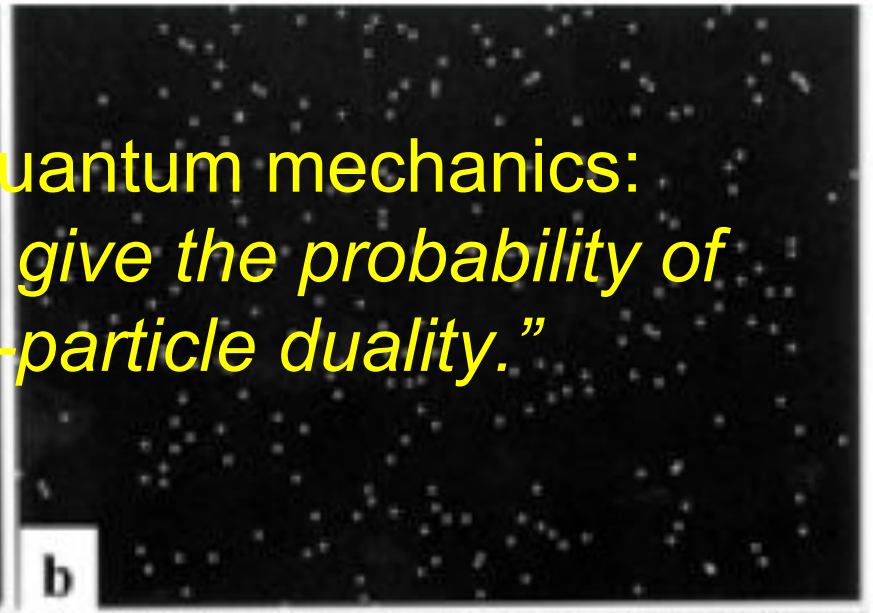
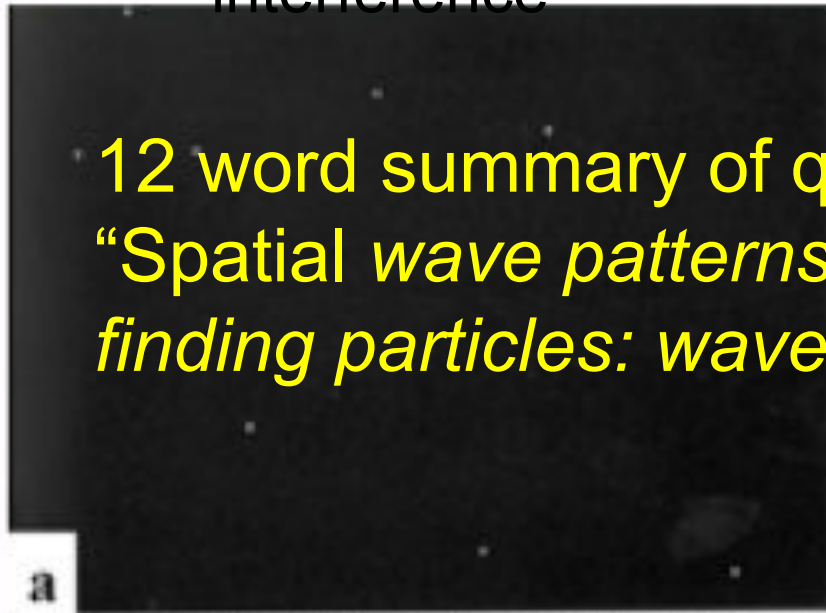

Linear Amplitude, Solar and Terrestrial

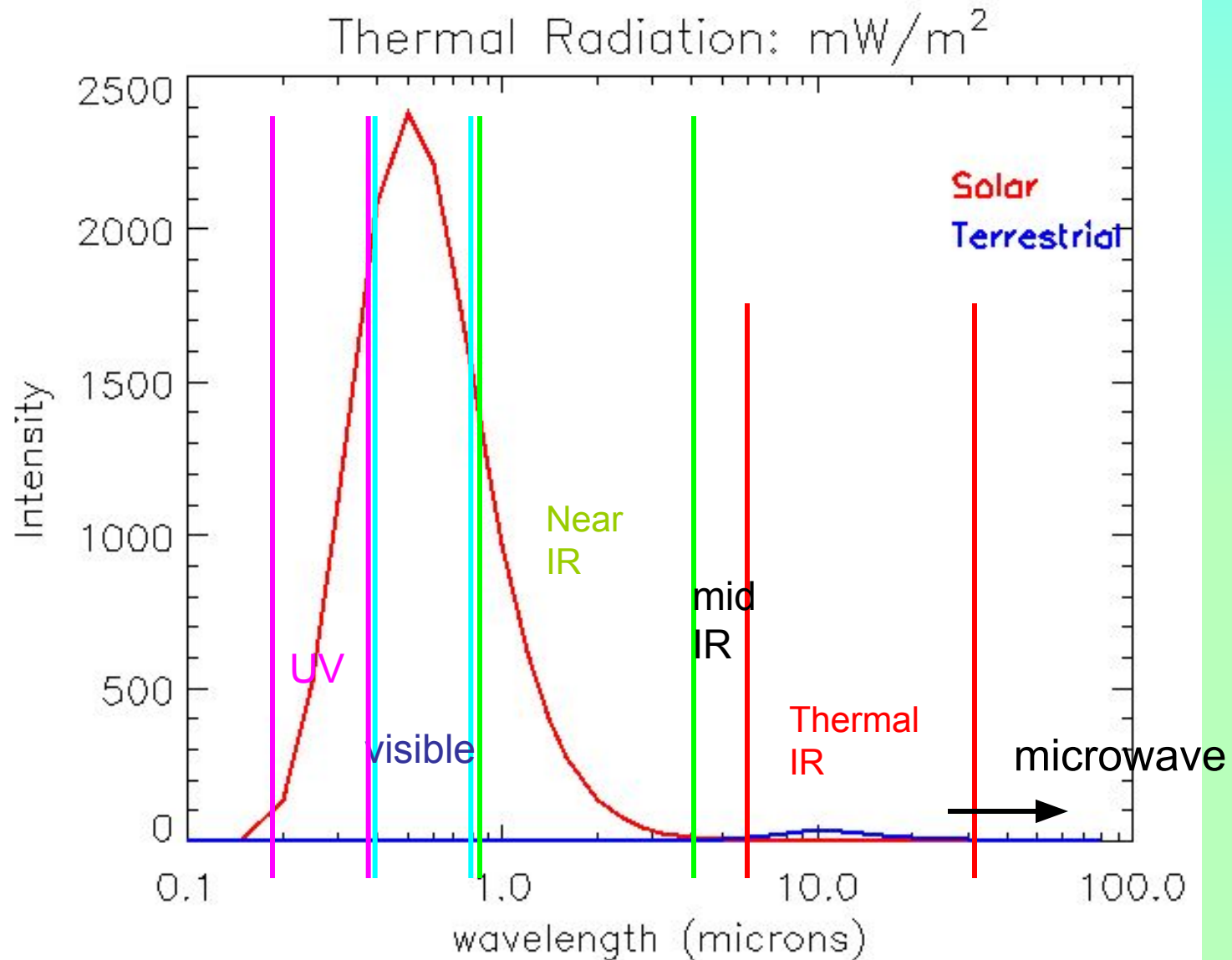

Solar Spectrum - absorption

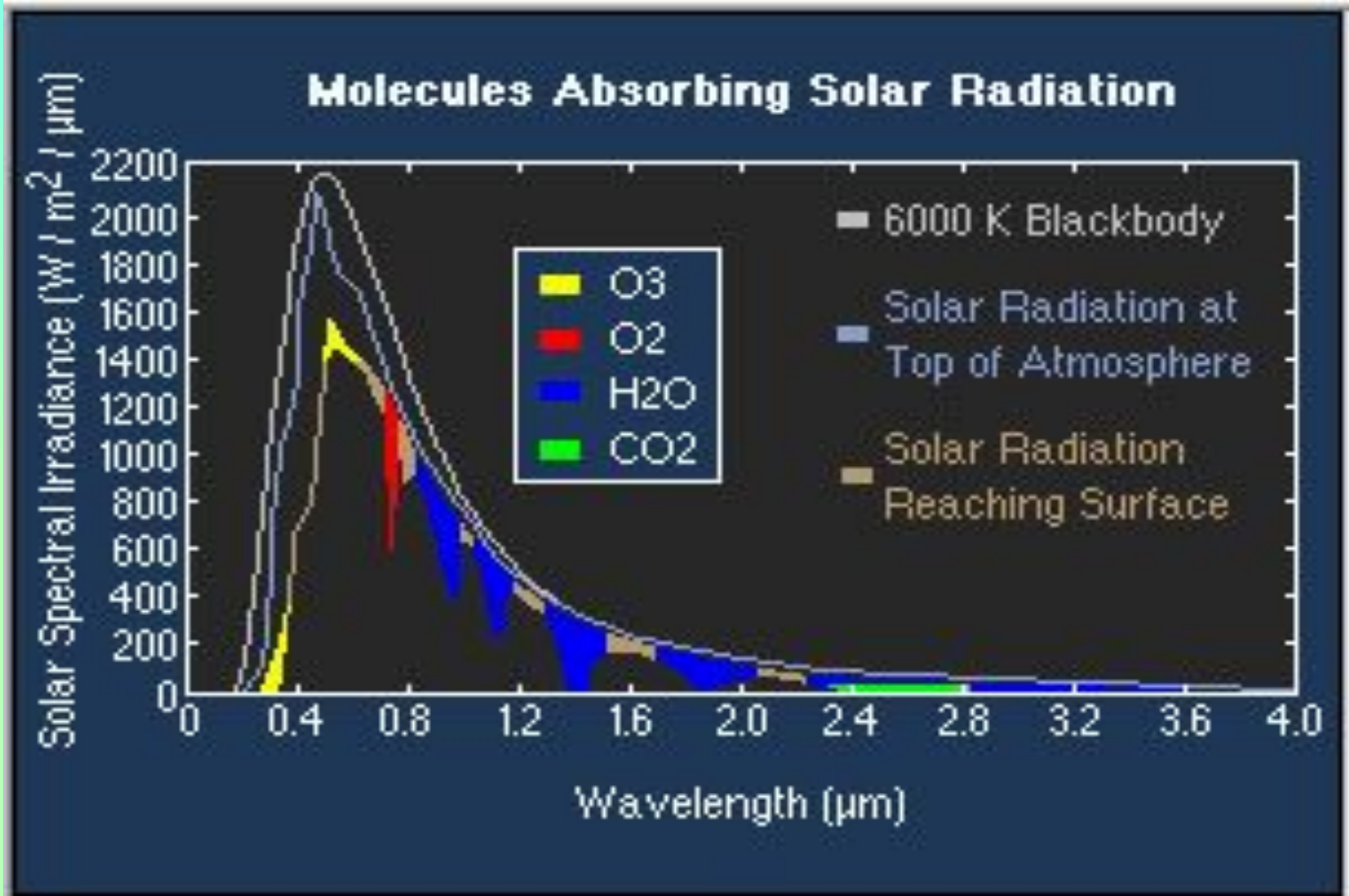

Some Scales to Know

Angstroms = 10^{-10} m. Atoms, molecules, hard X-rays

Microns = 10^{-6} m. Cells, pollution(aerosols),
cloud drops, solar spectrum
Visible light

mm = 10^{-3} m. Rain drops, microwaves.

A little Practice

- When a flute is played, a sound wave is formed inside. One peak is at the mouthpiece, the trough at other at the end. If the speed of sound is 340 m/s and and the length of a flute is 70 cm, what is the frequency of the lowest note it can play?
- You wave a charged balloon up and down a few times a second, what wavelength of light are you producing? What object has comparable size?

Measuring Light

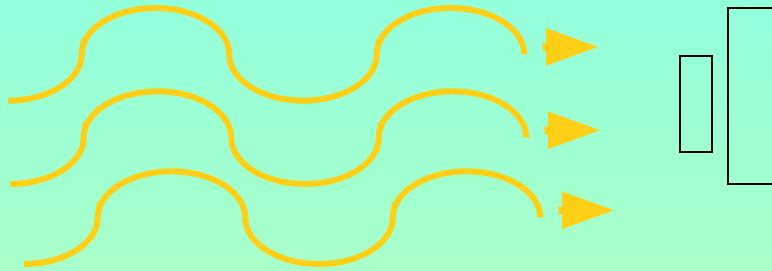

For the same intensity, the energy that passes increases with area.

Light waves transport energy at a rate given by its intensity.

For a given intensity, we expect the energy that passes through an area during a given time to be given by

Energy = intensity x area x time or Intensity = $E/(AT)$

But Energy/time = power (watts) so $I = P/A \Rightarrow W/m^2$

Variations on Intensity

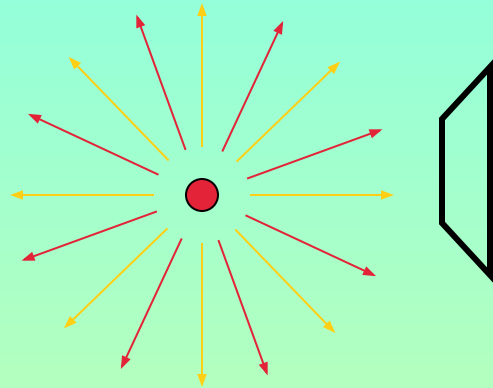

Intensity is measured as power/area that passes through an imaginary surface perpendicular to the light. $I = \text{watts/m}^2$

Intensity can also be measured per unit wavelength to capture a section of the spectrum.

spectral intensity $I = \text{watts/m}^2/\mu\text{m}$

Ideal Laser beam:



A Physical Analogy

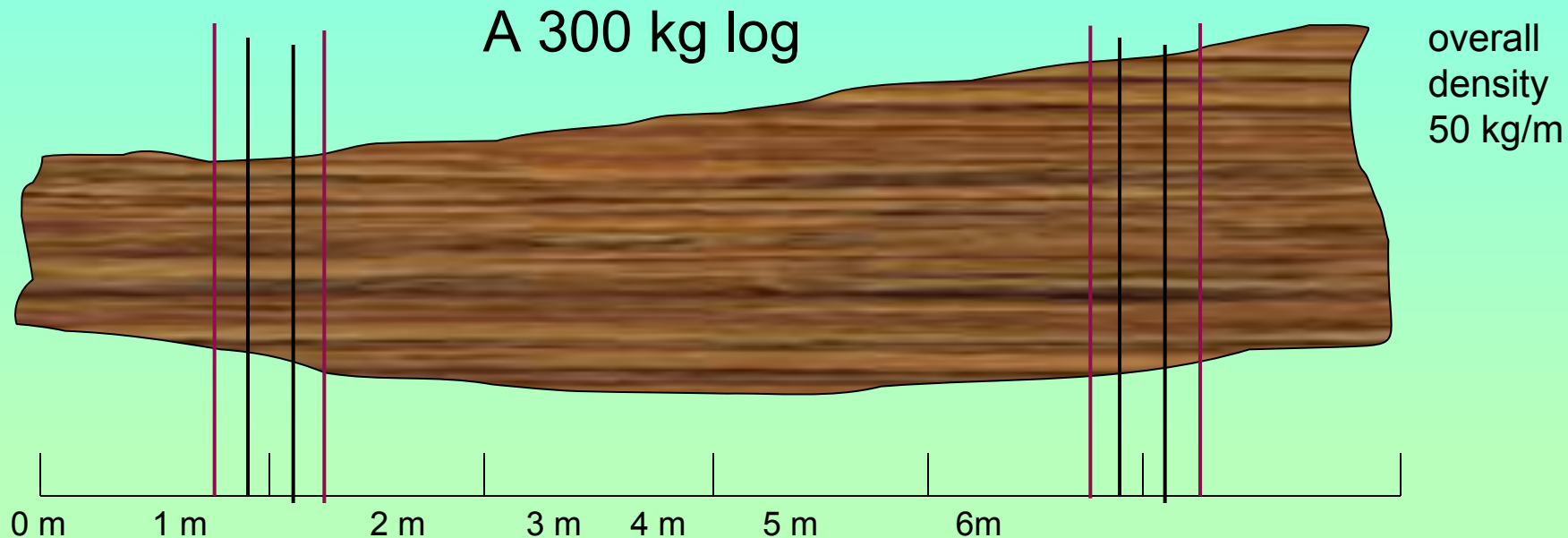

Density at 1 m:
= $8 \text{ kg}/(1.1\text{m} - 0.9 \text{ m})$
= 40 kg/m

Density at 1 m:
= $16 \text{ kg}/(1.2\text{m} - 0.8 \text{ m})$
= 40 kg/m

Density at 5 m:
= $12 \text{ kg}/(5.1\text{m} - 4.9 \text{ m})$
= 60 kg/m

Density at 5 m:
= $24 \text{ kg}/(5.2\text{m} - 4.8 \text{ m})$
= 60 kg/m

Intensity and Wavelength

Intensity = 1400 W/m^2

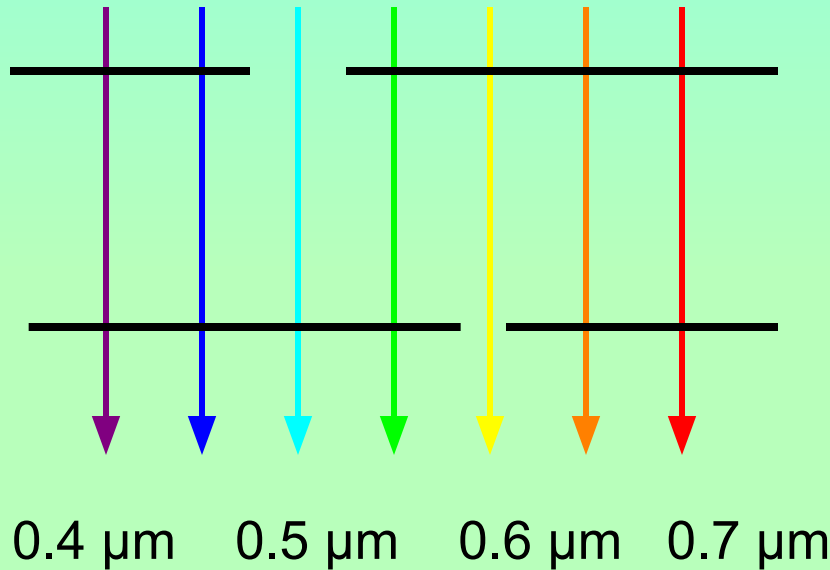

At $0.5 \mu\text{m}$,

$$\begin{aligned} \text{Spectral intensity} &= \\ &= (200 \text{ W/m}^2) / (0.55 \mu\text{m} - 0.45 \mu\text{m}) \\ &= 2000 \text{ W/m}^2/\mu\text{m} \end{aligned}$$

At $0.6 \mu\text{m}$,

$$\begin{aligned} \text{Spectral intensity} &= \\ &= (60 \text{ W/m}^2) / (0.62 \mu\text{m} - 0.58 \mu\text{m}) \\ &= 1500 \text{ W/m}^2/\mu\text{m} \end{aligned}$$

Spectral Intensity Example

A detector with an area of 2 cm² measures power of 0.14 watts. It is sensitive to wavelengths between 0.4 and 0.8 microns. What is the spectral intensity of this light?

$$\begin{aligned} I_{\lambda} &= (\text{power/area})/\Delta\lambda = ((0.14 \text{ watts})/(2 \text{ cm}^2))/(0.8 - 0.4 \text{ } \mu\text{m}) \\ &= (1.4 \times 10^{-1} \text{ W})/(2 \times (10^{-2} \text{ m})^2)/(4 \times 10^{-1} \text{ } \mu\text{m}) \\ &= \frac{(1.4 \times 10^{-1} \text{ W})}{(2 \times 10^{-2} \text{ m})^2 (4 \times 10^{-1} \text{ } \mu\text{m})} = 0.175 \times 10^4 \frac{\text{W}}{\text{m}^2 \text{ } \mu\text{m}} = 1.75 \times 10^3 \text{ W/m}^2 / \mu\text{m} \end{aligned}$$

A Note on Radiance

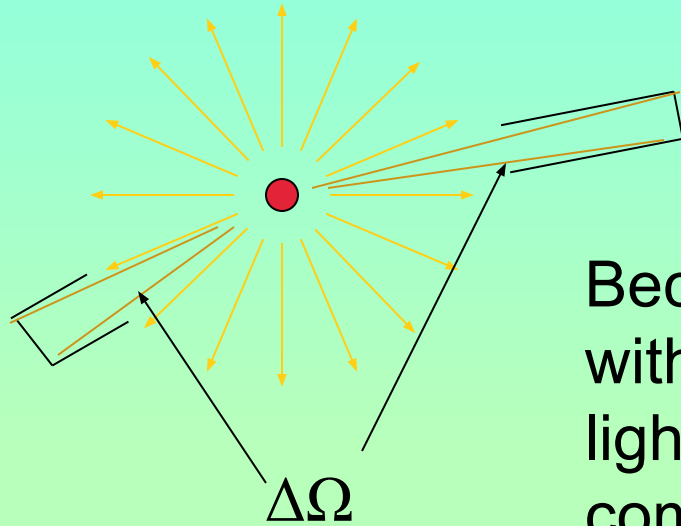

Because detectors collect light within a narrow angular range (and light radiates in all directions) it's common to talk about the light per unit solid angle, or *radiance*.

$$I_{\text{rad}} = I/\Delta\Omega$$

How to think about radiance

“ $I = 60 \text{ W/m}^2/\mu\text{m/ster}$ at a wavelength of $0.6 \mu\text{m}$ in a given direction”

Means:

We are measuring light with a certain instrument.

After figuring out how much power was in the light, we divided by the area of the detector.

The detector measures light over a certain range centered on $0.6 \mu\text{m}$.

So if the detector measures light between 0.54 and $0.66 \mu\text{m}$, we divided by $0.12 \mu\text{m}$ to get the light per unit wavelength.

Then we divided by the solid angle the detector samples.

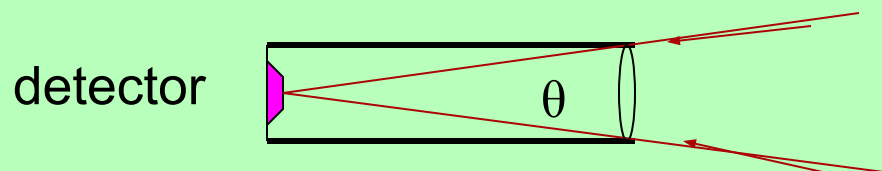

Every detector has a sampling angle

Light Intercepted by a Surface

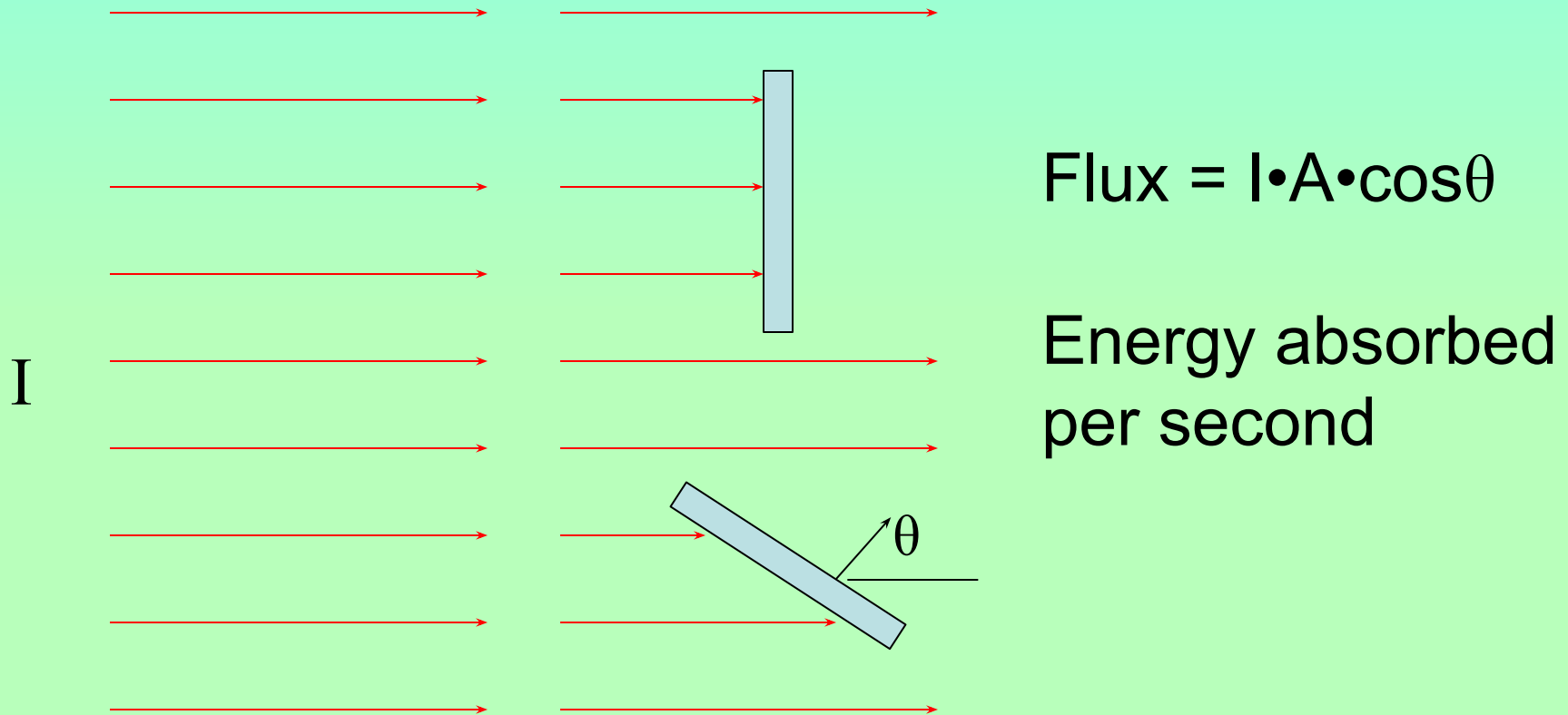

Equal areas, which intercepts more light energy?

Conservation of Energy

$$I = R + T + A$$

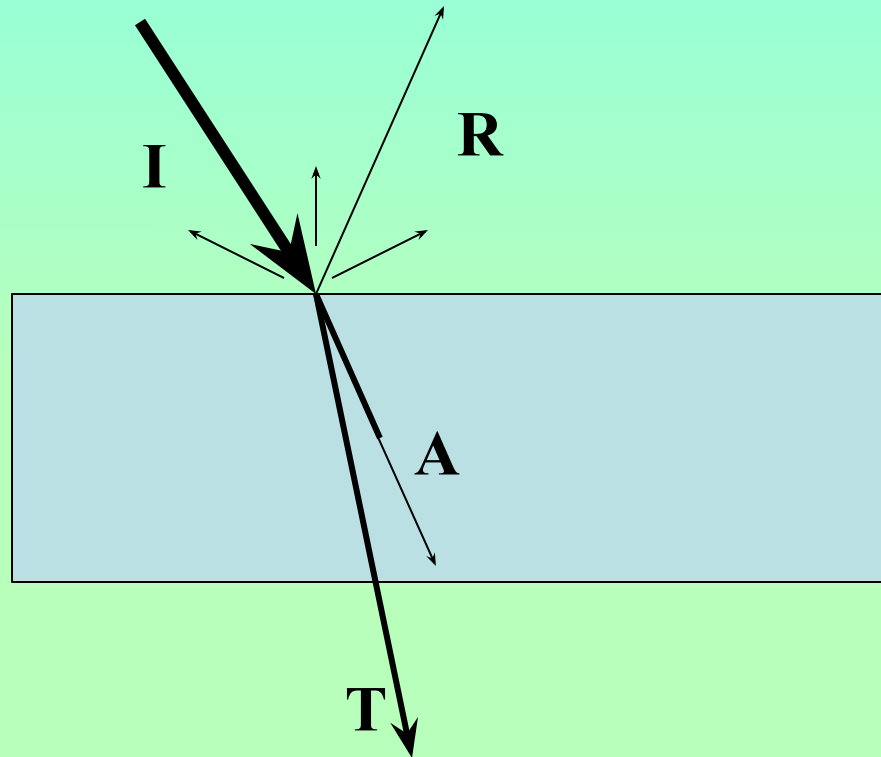

Insert some basic practice

Key Concept: Reflectance

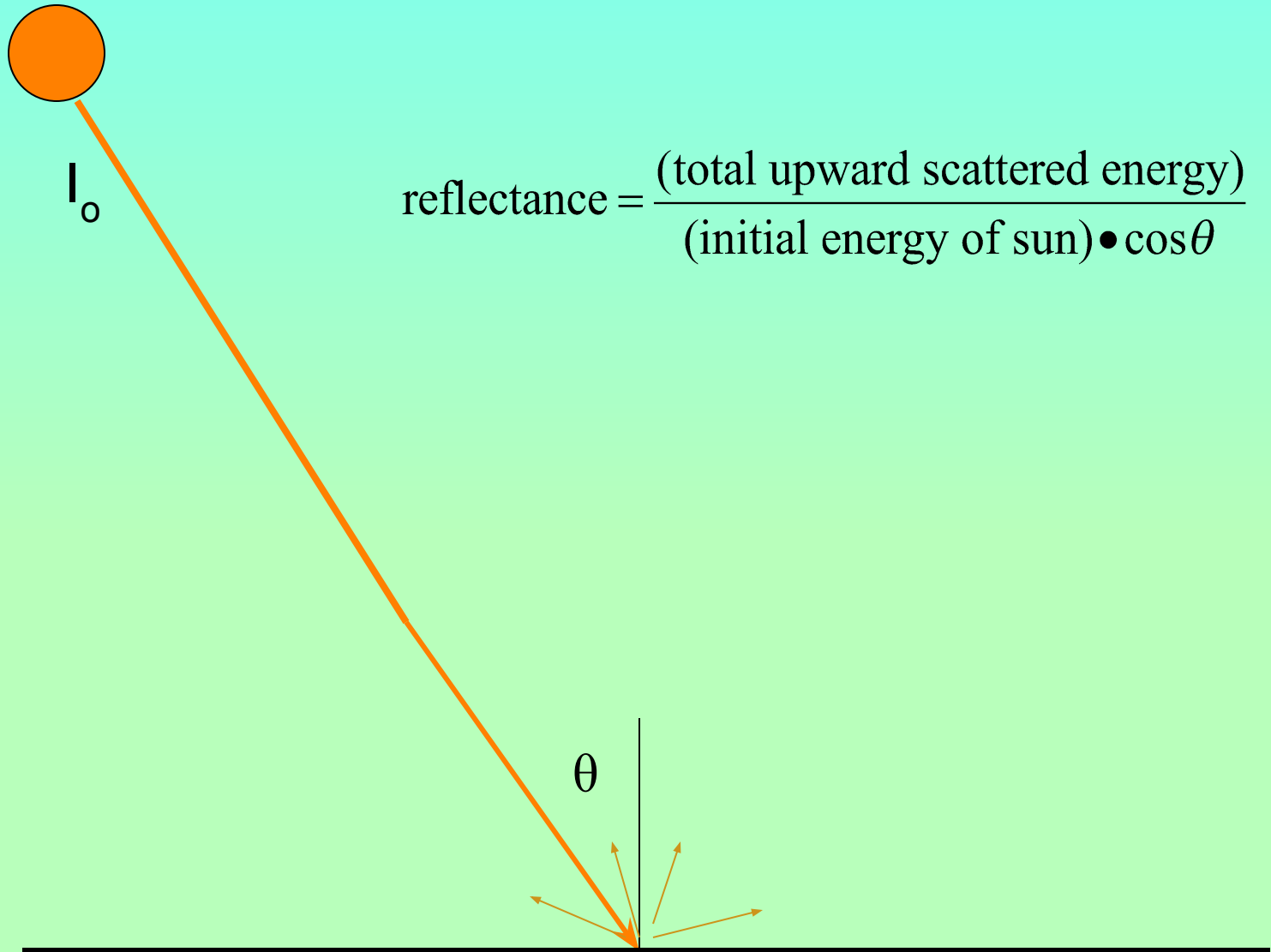

Notes on Reflectance

- Theoretically adjusts for sun angle over a horizontal surface, so reflectance is intrinsic to the surface, not time of day.
- Is a ratio that should go between 0 and 1, but since the scattering is not always uniform may be calculated to be larger than 1.
- As with all remote sensing, atmospheric correction for scattering and absorption should be done for accurate results.

Example: The intensity of sunlight once it passes through the atmosphere is about 1200 W/m^2 . If the sun is at an angle of 60 degrees from directly overhead, and 200 W/m^2 are being reflected, what is the reflectance?

$$r = \frac{I_{ref}}{I_0 \cos \theta} = \frac{200 \text{ W/m}^2}{(1200 \text{ W/m}^2) \cos(60^\circ)} = \frac{200}{600} = 1/3$$

How much light is being absorbed by a square of size $2\text{m} \times 3 \text{ m}$?

*Each square meter reflects $1/3$ of the light, so $2/3$ is absorbed.
Each square meter reflects 200 W , so 400 W is absorbed.
 6 square meters must absorb $(6 \text{ m}^2) \times (400 \text{ W/m}^2) = 2400 \text{ W}$.*

A more realistic scenario

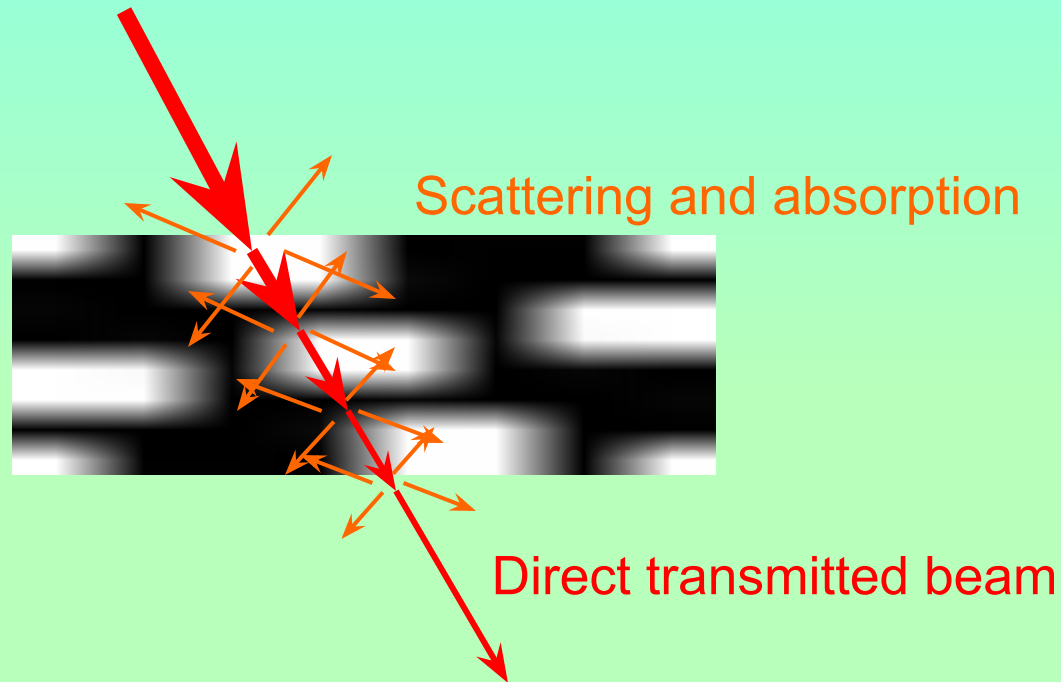

- Light is scattered in all directions, not simply reflected
- Scattering, absorption occurs throughout, not just surfaces

Some Classwork

1. Break into teams, each with a paper towel roll. You want to predict the diameter of white board that is viewed through the tube, based on measurements that you make of the geometry.
2. Calculate the following:
 - Frequency of visible light based on the wavelength.
 - Wavelength of a radio station broadcasting at 91.5 Mhz
3. Sunlight has an intensity of 1340 W/m^2 . If it is 35 degrees above the horizon and the reflectance of grass is 0.2, what would be the intensity of light reflected off a football field? What would be the energy absorbed per square meter? Energy absorbed by the whole field?

Classwork Scoring (out of 20 pts)

- 6 pts for overall presentation style: diagrams, explanation of reasoning, symbolic algebra, keeping track of units and powers of 10
- 2 pts for each correct problem solution, with fractional credit.

Atmospheric Correction

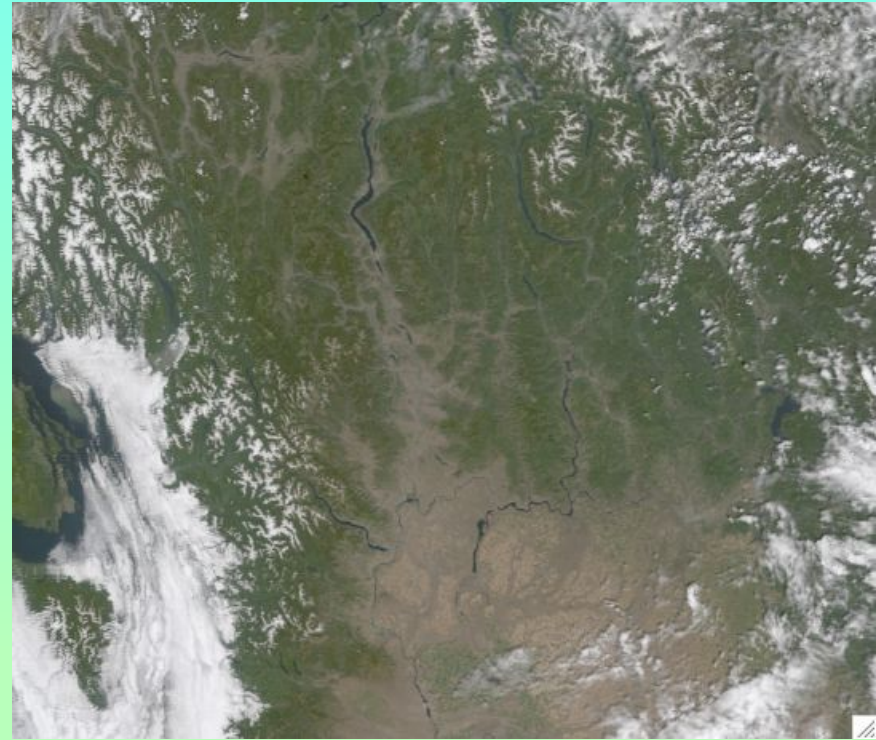
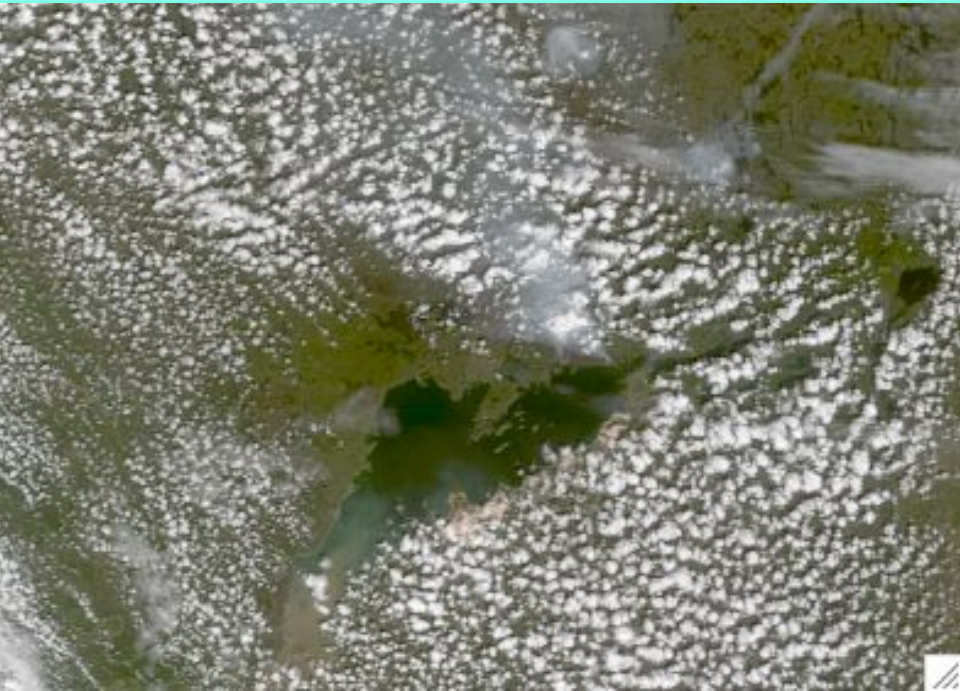

If you want to look at anything other than the atmosphere, you must subtract out the effect of the atmosphere. We must account for extinction and 'path radiance' (light scattered into the beam).

Normalized Difference Vegetation Index

High absorption in the red with high reflectance in the near infrared (NIR) is characteristic of chlorophyll.

$$NDVI = \frac{NIR - RED}{NIR + RED}$$

$$-1 < NDVI < 1$$

High NDVI indicates vegetation density

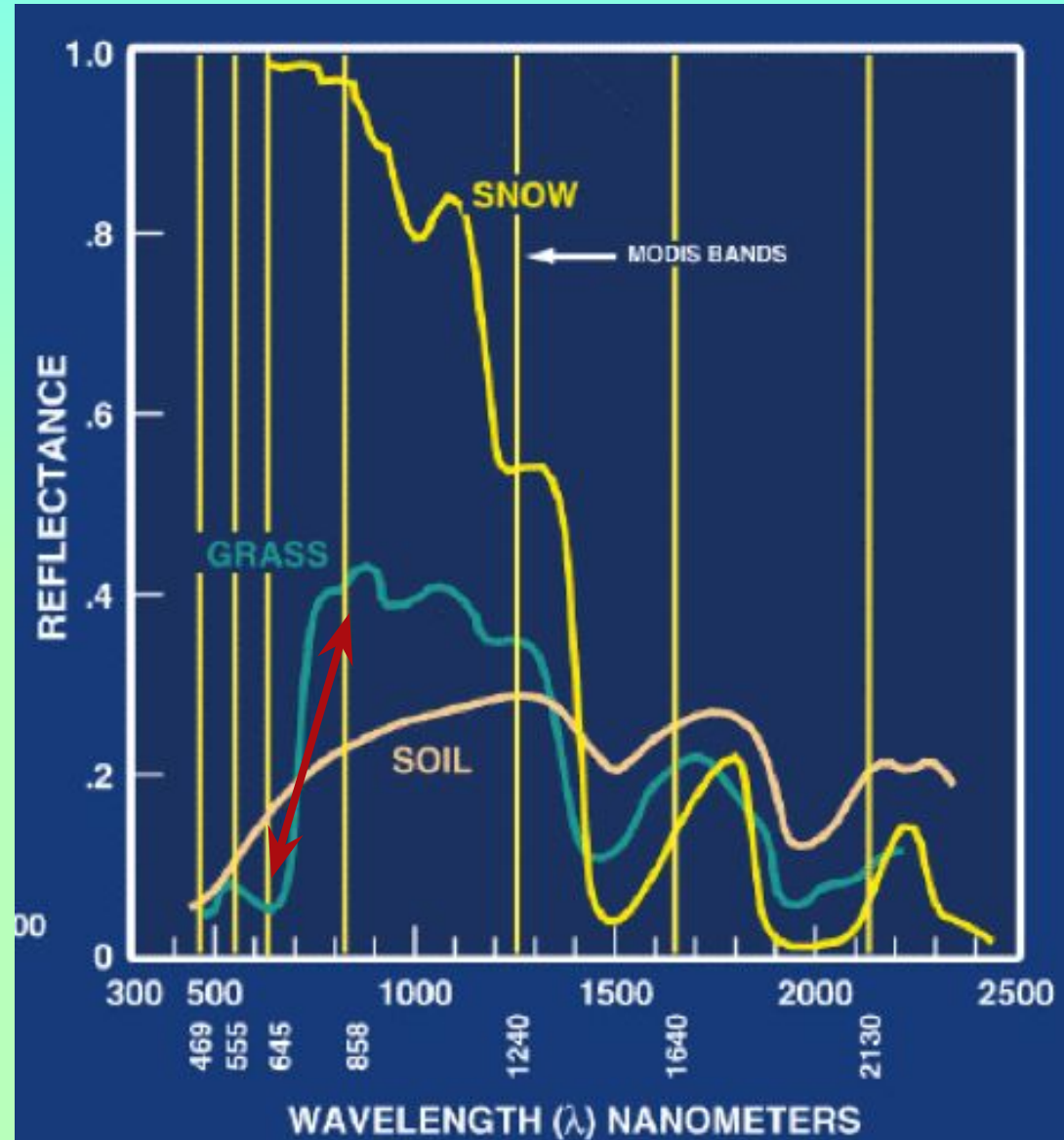

Vegetation by Satellite

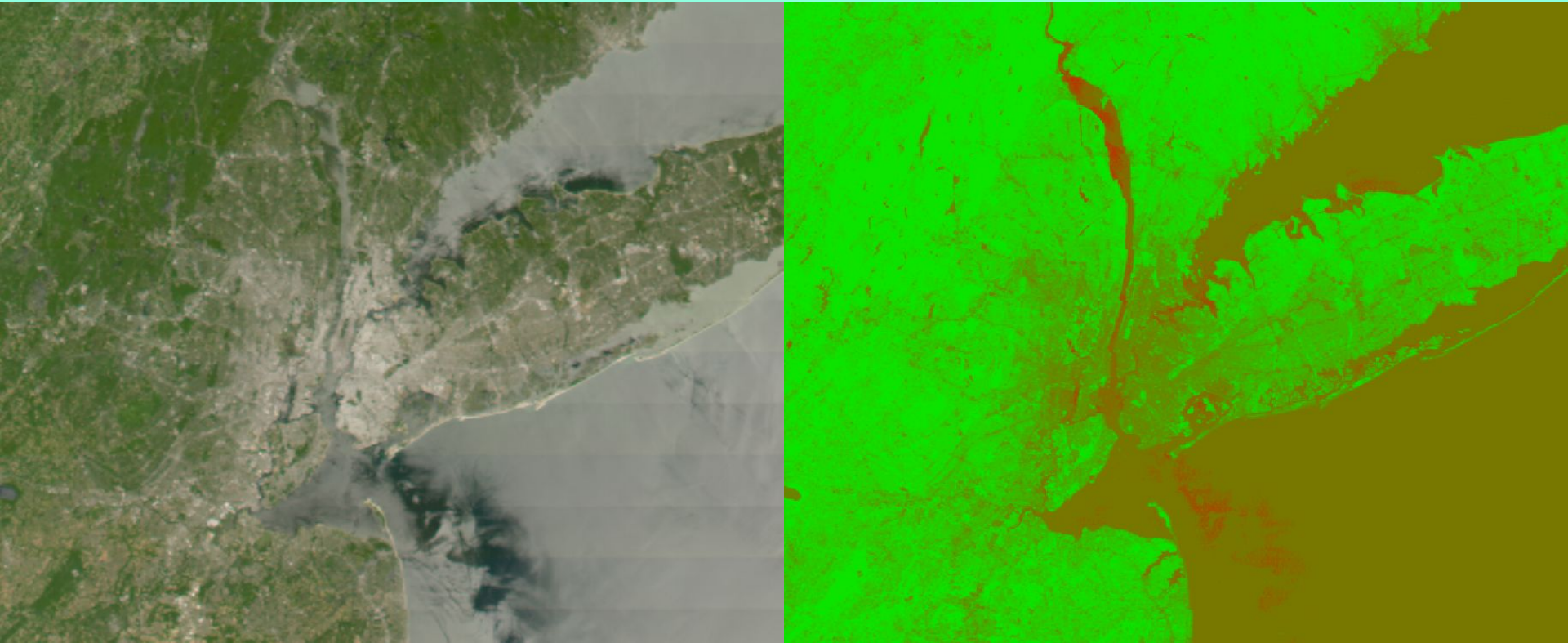

Visible RGB

500 m resolution

NDVI: red is negative

250 m resolution

Classwork 2

Add a function to your `landsat_module` that will do the following:

1. Take red and NIR as inputs
2. Produce an array of NDVI as output
3. Make a map of NDVI in shades of green and save it.

The function must work when tested.

$$NDVI = \frac{NIR - RED}{NIR + RED}$$

Further Concepts

Everything from here on out is to help you understand the science behind some projects, but we don't have enough time to expect it to sink in; so just enjoy the discussion as a sort of science entertainment.

Black Demo Screen for Ripple Tank

Double slit: 2:30 4:45

Waves, Charged Scatterers, and Interference Patterns

Driving wave

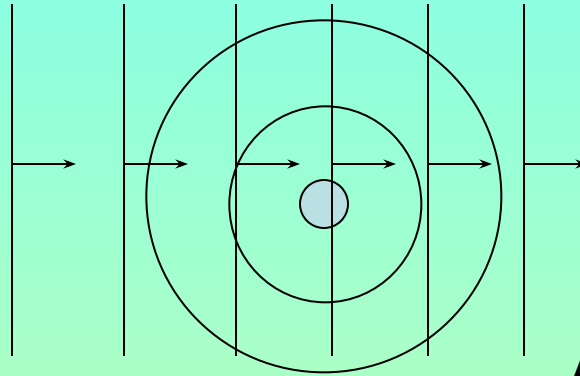

A single charge responds with a circular wave.

Driving wave

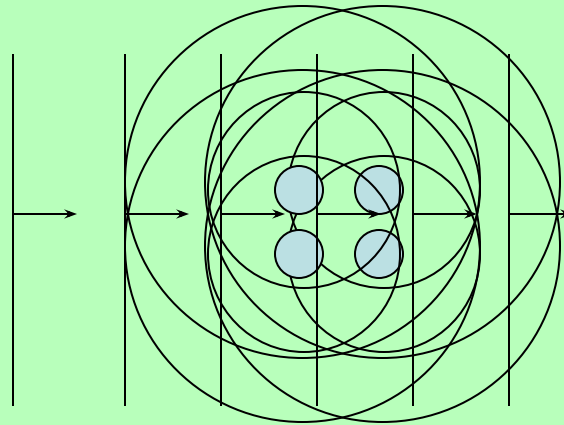

A collection of charges will produce a more complex pattern.

Rayleigh Scattering

Wavelength \gg radius
(all charges in same part of wave)

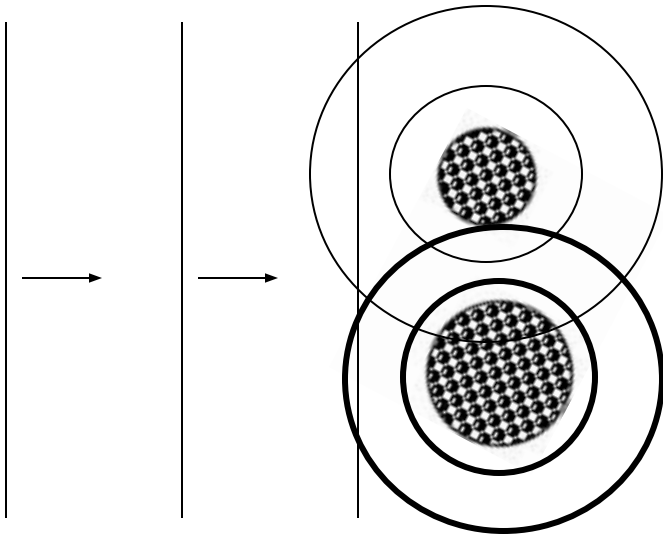

The amount of scattered energy increases with the amount of charge, which increases with volume. So scattered energy increases faster than the cross sectional area.

Milk Scattering Demo

Online demo

Weather Radar

cm waves with mm raindrops
equals Rayleigh Scattering!
(cloud drops too small to matter)

The Basic Idea

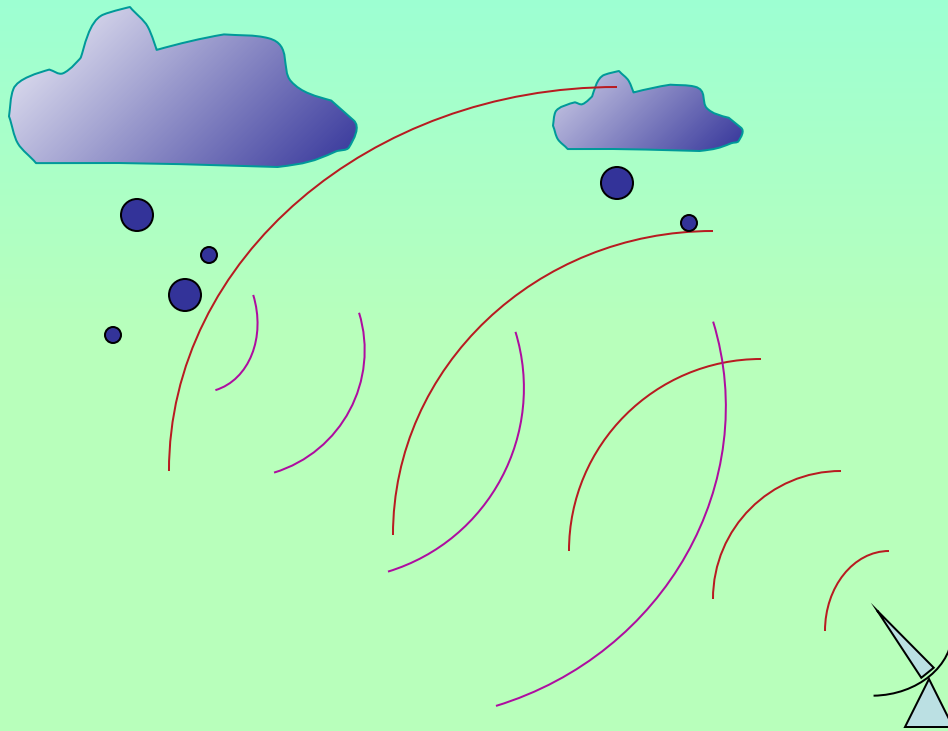

The *time* it takes a signal to return is used to calculate the distance.

The *intensity* of the returned signal is used to calculate the amount of rainfall.

Geometrical Scattering

wavelength \ll radius
(wave effects average out)

We'd like to think the light rays act like little bullets instead of waves; only those intercepted by the object are affected.

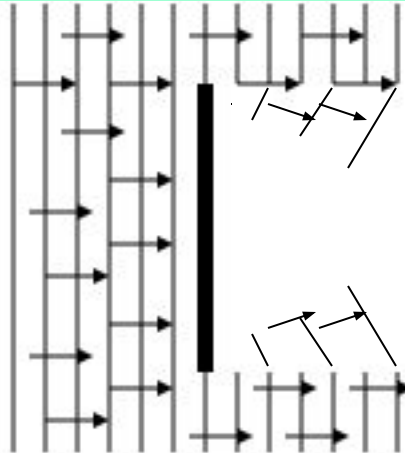

In this case the optical cross section would just equal the cross sectional area.

Geometrical Scattering is independent of wavelength.

In reality some waves will always bend around the edges of an object, so there's no such thing as pure geometrical scattering.

Things to Know: Scattering

- If the particle is very, very much smaller than the wavelength, you can ignore the scattering. Weather radar uses this to see raindrops, not cloud drops.
- If particles are several times smaller than the wavelength, scattering increases rapidly with size (more charges to oscillate!). Scatters in all directions. This makes our sky blue: molecules scatter shorter waves.
- If the particle is close to the size of the wavelength, the scattering can be strong but complicated.
- If the particle is more than several times larger than the wavelength, scattering is proportional to cross sectional area (geometrical scattering). Mainly scatters forwards (transmission). This is our everyday world.

Key Concept: Optical Depth

- Tells you what fraction of light will be affected. When small, the fraction IS the optical depth. Approaches 1 as optical depth increases.
- Can be thought of as the average number of times a photon will strike the material it passes through.
- The optical depth of a material changes with wavelength because absorption and scattering changes with wavelength - even though the material stays the same.

Optical Depth and Probability

Optical depth is the amount of stuff in light beam, and how strongly it interacts

Non-random layers

random layers (reality)

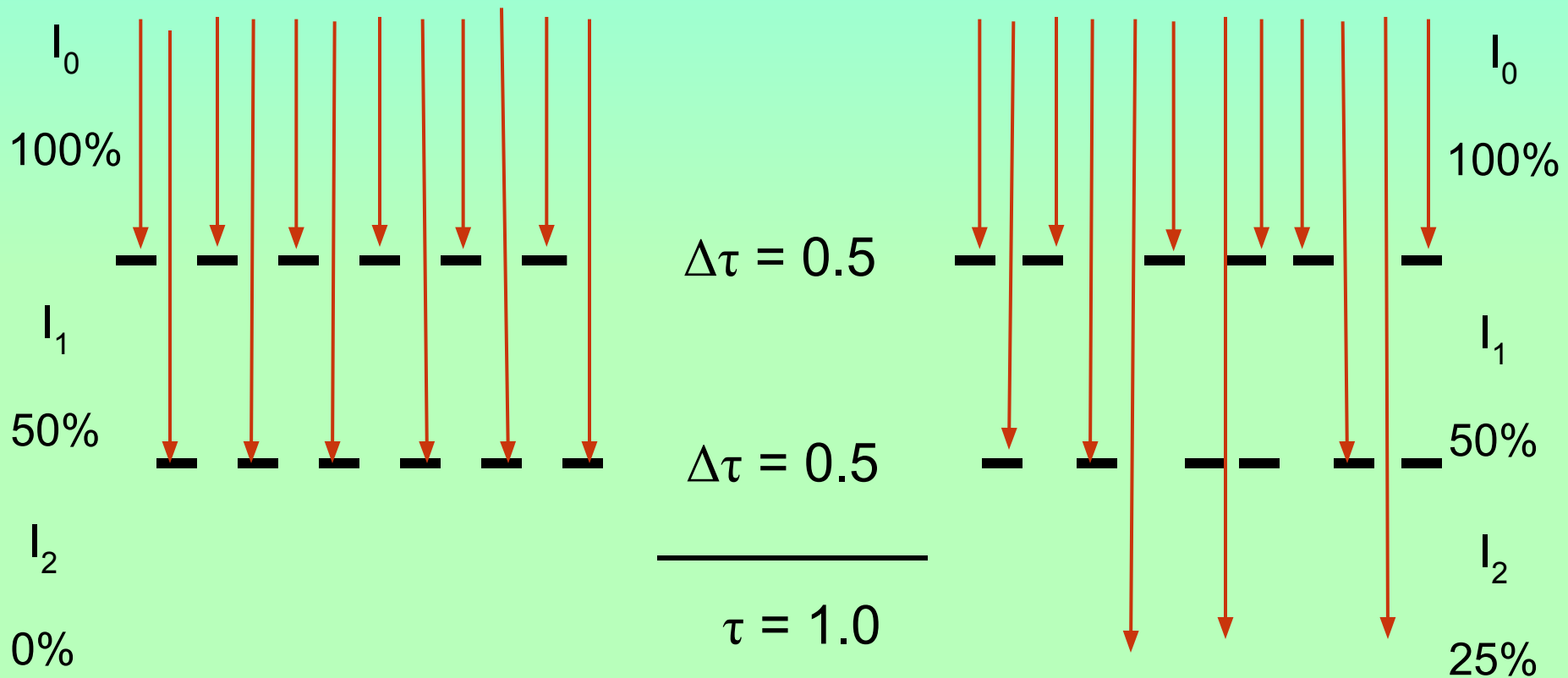

Purely Absorbing Material: Exponential Decay

The symbol for optical depth is τ ; Δ means “change in”

$$\Delta I = I_1 - I_0 = -I_0 \Delta\tau \quad \Rightarrow \quad I_1 = I_0 (1 - \Delta\tau)$$

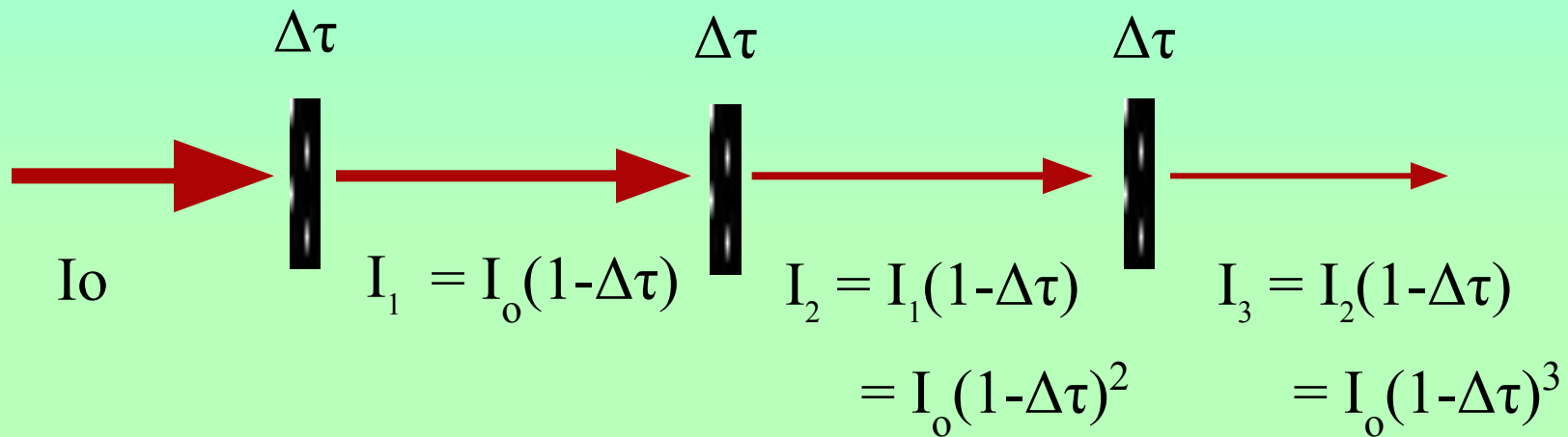

$$\text{But } \tau = n\Delta\tau \quad \text{so } I_n = I(\tau) = I_0(1 - \Delta\tau)^n = I_0(1 - \tau/n)^n$$

So as Optical Depth Increases...

Optical depth is the amount of stuff in the way of a light beam, multiplied by how strongly it interacts with light at a given wavelength.

Transmission: **decreases**

Scattering: **increases**

Absorption: **increases**

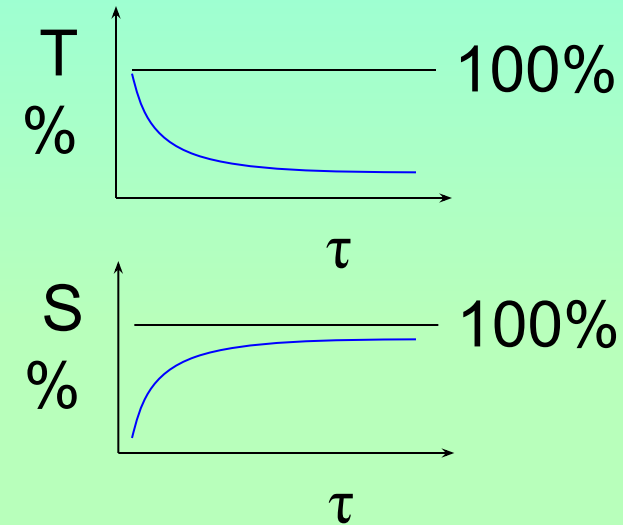

All asymptotically towards their ultimate value